

# Standard Tensile Link

## SL-3.0

The SL-3.0 is a cable connected Tensile Link available with capacities ranging from 1t to 500t. These devices can be used in various tension load monitoring applications for industries worldwide and combine high levels of performance with excellent value.

The link comes complete supplied in a carrying/stowage case by capacity with a standard 10m signal cable and a battery powered TW-3.0-S display.



### Dimensional Data

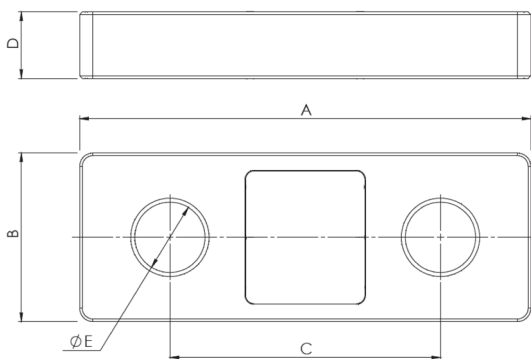

### Features:

- Light weight aerospace grade aluminium
- High accuracy
- Rebranding option
- Wide range of capacities

Load Capacity (Tonnes)	Shackles	Part Number	A	B	C	D	ØE	Accuracy (% FRO)	Proof test (% Load Capacity)	Weight (Kg)	Default Resolution (Kg)
1	Crosby G2130	0001 – 1320	214	81	174	16	16.5	0.2	150	1.0	1
2	Crosby G2130	0001 – 1321	214	81	174	16	16.5	0.2	150	1.0	1
5	Crosby G2130	0001 – 1322	260	109	180	25	28	0.2	150	2.0	1
12	Crosby G2130	0001 – 1323	260	109	165	40	38	0.2	150	2.6	5
17	Crosby G2130	0001 – 1324	320	127	204	45	44	0.2	150	4.0	5
25	Crosby G2130	0001 – 1325	340	127	204	50	53	0.2	150	5.0	10
35	Crosby G2130	0001 – 1326	370	149	210	50	60	0.2	150	6.5	10
50	Crosby G2130	0001 – 1327	395	160	220	73	73	0.2	150	11	50
80	GN H9	0001 – 1328	465	180	250	98	86	0.2	150	18	100
100	GN H10	0001 – 1329	535	220	275	100	99	0.3	150	26.5	100
120	GN H10	0001 – 1330	535	220	275	100	99	0.3	150	29.5	100
150	GN H10	0001 – 1331	587	260	295	125	112	0.3	150	43.5	100
200	GN H10	0001 – 1332	658	320	320	125	128	0.5	150	62.0	100
300	GN H10	0001 – 1334	790	370	380	147	154	0.5	150	100.5	100
400	GN H10	0001 – 1336	950	500	500	175	180	1.0	150	200.0	100
500	GN H10	0001 – 1338	950	500	500	200	190	1.0	150	220.5	100

### Specification

Link Material:	Aluminium
Bridge Resistance:	700Ω - 1000Ω
Operating Temperature Range:	-20°C to +60°C
Handheld Display	TW-3.0 cable connected Handheld Display
Cable:	Mil Spec/Tajimi termination. 10m signal cable standard
Calibration:	Supplied with calibration, proof load and test certificates to traceable to UKCA BS EN ISO 7500-1 2018
Packaging:	Rugged and watertight case for links up to 50 tons. Custom made wooden case for larger capacities
Approvals	UKCA and CE tested and compliant