

S Cell Load Cell

SC-1.0

S Cell - 250kg - 20,000kg.

Dimensional Data

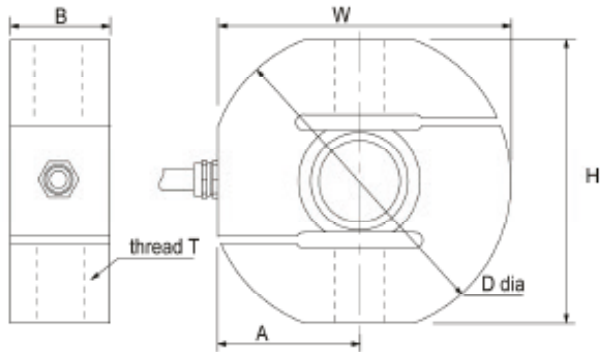

*Rod End Bearings sold separately

Features:

- Welded covers
- Stainless steel
- Sealed to IP68
- Tension and compression
- High accuracy

Applications:

- Test stands
- Certification
- Vessel and tank weighing
- Retro fitting in OEM equipment

Capacity (kg)	Part Number	A	W	H	B	ØD	Thread T
250	0001-1052	35	72.5	70	24.5	75	M12x1.75
500	0001-1053	35	72.5	70	24.5	75	M12x1.75
1000	0001-1054	45	95	95	30	100	M20x1.5
2000	0001-1055	45	95	95	30	100	M20x1.5
5000	0001-1056	57.5	120	120	40	125	M24x2
10000	0001-1057	65	141	145	55	152	M30x2
20000	0001-1058	88	188	190	70	200	M45x3

Options: Eye-bolts, compression fittings and instrumentation.
Please enquire for details.

Specification

Capacities	250kg / 500kg / 1000kg / 2000kg / 5000kg / 10000kg / 20000kg
Full Load Output	2.0 ($\pm 0.25\%$) mV/V
Zero Load Output	$< \pm 2.0\%$
Excitation (Max)	10 (15) V
Accuracy	$< 0.03\%$
Repeatability	$< 0.01\%$
Input Resistance	410 (± 30) Ω
Output Resistance	350 (± 2) Ω
Compensated Temp. Range	-10 to +40 °C
Operating Temp. Range	-20 to +60 °C
Temp. Coefficient on Zero	$< 0.0015\%$ Capacity/°C
Temp Coefficient on Span	$< 0.002\%$ Capacity/°C
Safe Overload	150 %
Insulation	500M Ω @ 100Vdc
Environmental Protection	IP68

