

Telemetry Tensile Link

TL-3.0

The TL-3.0 is a third generation Telemetry Tensile Link load cell. A light weight wireless tension measuring unit that combines a high level of performance with a robust design for harsh environments.

With a range up to 800m and a huge battery life of 700 hours the TL-3.0 can be paired with one or a multiple number of TW-3.0-T Telemetry Handheld Displays.



Dimensional Data

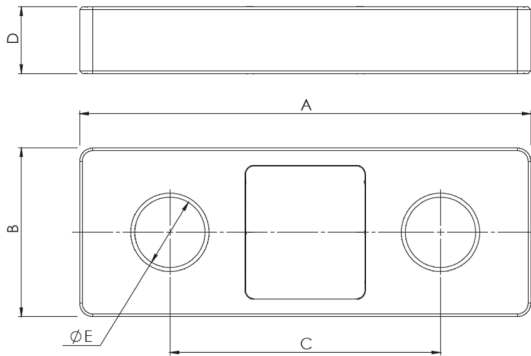

Features:

- Light weight aerospace grade aluminium
- 2.4GHz licence free frequency
- High accuracy
- Rebranding option
- 800m signal range
- Remote power on/off feature
- Sleep mode for battery conservation

Load Capacity (Tonnes)	Part Number	Shackles	A	B	C	D	ØE	Accuracy (% FRO)	Proof test % Load Capacity	Weight (kg)	Default Resolution (kg)
1	0001 – 1300	Crosby G2130	214	81	174	16	16.5	0.2	150	1.0	1
2	0001 – 1301	Crosby G2130	214	81	174	16	16.5	0.2	150	1.0	1
5	0001 – 1302	Crosby G2130	260	109	180	25	28	0.2	150	2.0	1
12	0001 – 1303	Crosby G2130	260	109	165	40	38	0.2	150	2.6	5
17	0001 – 1304	Crosby G2130	320	127	204	45	44	0.2	150	4.0	5
25	0001 – 1305	Crosby G2130	340	127	204	50	53	0.2	150	5.0	10
35	0001 – 1306	Crosby G2130	370	149	210	50	60	0.2	150	6.5	10
50	0001 – 1307	Crosby G2130	395	160	220	73	73	0.2	150	11	50
80	0001 – 1308	GN H9	465	180	250	98	86	0.2	150	18	100
100	0001 – 1309	GN H10	535	220	275	100	99	0.3	150	26.5	100
120	0001 – 1310	GN H10	535	240	275	100	99	0.3	150	29.5	100
150	0001 – 1311	GN H10	587	260	295	125	112	0.3	150	43.5	100
200	0001 – 1312	GN H10	658	320	320	125	128	0.5	150	62.0	100
300	0001 – 1314	GN H10	790	370	380	147	154	0.5	150	100.5	100
400	0001 – 1316	GN H10	950	500	500	175	180	1.0	150	200.0	100
500	0001 – 1318	GN H10	950	500	500	200	190	1.0	150	220.5	100

Specification

Link Material:	Aluminium
Design:	Holes designed to fit fed spec shackles / Pairing switch / Signal LED / Charging socket
Bridge Resistance:	700Ω
Battery:	1 x3.7V Li-Po rechargeable
Battery Life:	700 hours continuous (2 years non-operational)
Charger:	Supplied with USB Charger
Operating Temperature:	-20°C to +60°C
Handheld Display:	One or more TW3.0- T displays
Frequency:	2.4GHz
Range:	Up to 800m range (line of sight)
Calibration:	Supplied with calibration, proof load and test certificates to traceable to UKCA BS EN ISO 7500-1 2018
Protection:	IP65
Packaging:	Rugged and watertight case for links up to 50T / Custom made wooden case for larger capacities
Approvals:	UKCA, CE, FCC and IC tested and compliant