

Son of Sammy

A round bottom grapnel consisting of six hooks positioned centrally around a main shank. Its design being based on the original long prong sand grapnel.

It can be manufactured with fixed hooks where space isn't a problem or folding where the hooks can be stowed during periods of non-use. The square cross section of the hooks provides increased holding capacity during operations in soft seabed conditions.

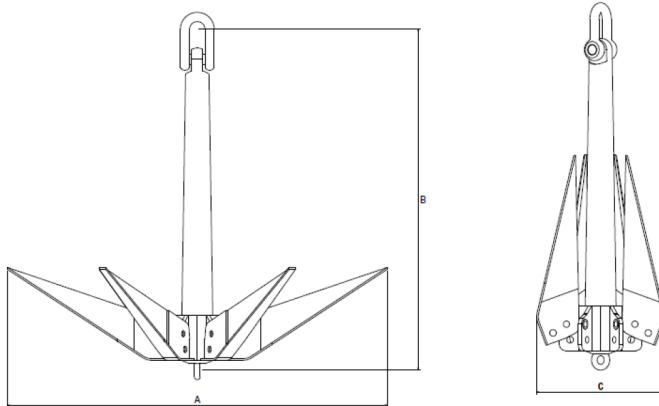
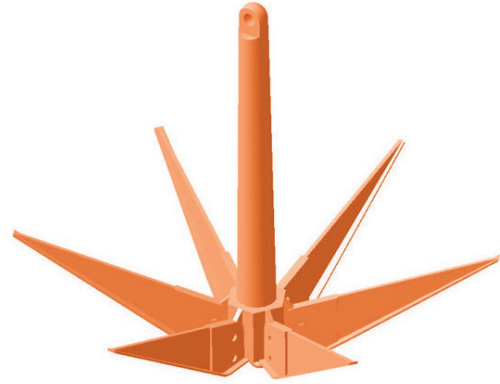

Features:

- One metre plus penetration available in applicable seabed types.
- Can be used in in clay and sand type seabed
- Multi hook design provides increased cable recovery opportunities
- Good cable holding properties due to hook design
- Two types available, fixed and folding

Applications:

- Recovery of buried cables in a variety of seabeds

Dimensions

Part Number	Description	A	B	C	WLL	Proof Load
0001-1180	Son of Sammy (Folding)	2300mm	1965mm	792mm	15t	22.5t
0001-1179	Son of Sammy fixed	2500mm	1640mm	N/A	15t	22.5t

Spares and Accessories Table

Part Number	Description
0050-0696	35t Shackle

*Not supplied with shackles